



INDUSTRIAL SHIELDS

**USER GUIDE**

**TOUCH PANEL PC 10.1"**



## Panel 10.1” User Guide:

### 1 Contents

1	TOUCHBERRY PI 10.1” (Raspberry PI 4B) .....	3
1.1	Controller Specifications: .....	3
1.2	Touchberry Pi 4 B I/Os Pinout .....	5
2	Tinker Touch.....	7
2.1	Controller Specifications: .....	7
2.2	Tinker Board Touch Pi I/Os Pinout.....	8
3	General Specifications .....	9
4	Touch Screen Specifications.....	9
5	Power Supply .....	10
6	Communication Connections .....	11
7	Screen configuration.....	12
8	Touch Panels PC 10.1” Size:.....	13
9	Mechanical assembly configuration: .....	15
9.1	Panel mounting.....	15
9.2	Standard VESA .....	16
9.3	Trim Plate .....	16
10	Operating System on Touch Panels .....	18
10.1	Debian .....	18
10.2	How to create apps.....	18
10.3	Other interesting available software .....	19
10.4	Android .....	20
11	Kiosk Mode on Panel Touch 10.1”.....	20



## 1 TOUCHBERRY PI 10.1" (Raspberry Pi 4B)

### 1.1 Controller Specifications:

Panel PC based on Raspberry Pi board, encasing a 10.1" resistive Touch Screen for industrial environment using Linux (Raspbian).

PANEL PC  
10,1"

LINUX  
LINUX OPERATION  
SYSTEM

ARDUINO  
Compatible with  
Arduino IDE

COM  
Industrial  
Communications

Board	Raspberry Pi 4B
SoC	Broadcom BCM2837B0
CPU	Quad core 64-bit ARM-Cortex A72 running at 1.5GHz
GPU	Broadcom VideoCore VI
USB	(2) x USB2 Ports + (2) x USB3 Ports
Storage	(1) x Micro SD / MMC / SDIO slot
Network Communication	1x Gigabit Ethernet port (supports PoE with add-on PoE HAT) – (3) x TTL - SPI – I <sup>2</sup> C
Wireless Communication	802.11 b/g/n/ac Wireless LAN (2.4GHz and 5GHz ) and Bluetooth 5.0 with BLE
Low level devices	40-pin GPIO header, populated
IP Value	IP20
GPIO Voltage	3,3V
OS	Linux and Unix



- This Panel PC is based on GNU/Linux OS installed on a SD card. It has many interfaces built in: Ethernet, USB, WiFi... Windows 10 IoT is also supported.  
Using the Ethernet port or WiFi network you can remotely control all parameters, data and inputs/outputs of your control system.
- Furthermore, Touchberry PI comprises enough I/Os to replace PLCs on simple automation applications.
- Open protocols not only allow communication with other Industrial Shields PLCs, but also third-party devices and machinery.
- In complex systems you can create a network between several TOUCHBERRY PI. Providing integral supervision and control solution for entire production plants and real-time data at hand.

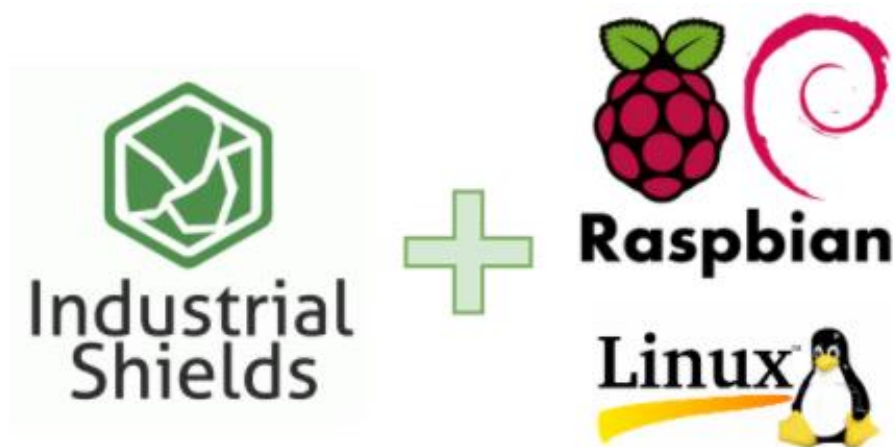



## 1.2 Touchberry Pi 4 B I/Os Pinout

The Raspberry Pi 4 model B pinout:

### Raspberry Pi 4 B J8 GPIO Header

Pin#	NAME		NAME	Pin#
01	3.3v DC Power		DC Power 5v	02
03	GPIO02 (SDA1, I <sup>2</sup> C)		DC Power 5v	04
05	GPIO03 (SCL1, I <sup>2</sup> C)		Ground	06
07	GPIO04 (GPCLK0)		(TXD0, UART) GPIO14	08
09	Ground		(RXD0, UART) GPIO15	10
11	GPIO17		(PWM0) GPIO18	12
13	GPIO27		Ground	14
15	GPIO22		GPIO23	16
17	3.3v DC Power		GPIO24	18
19	GPIO10 (SPI0_MOSI)		Ground	20
21	GPIO09 (SPI0_MISO)		GPIO25	22
23	GPIO11 (SPI0_CLK)		(SPI0_CE0_N) GPIO08	24
25	Ground		(SPI0_CE1_N) GPIO07	26
27	GPIO00 (SDA0, I <sup>2</sup> C)		(SCL0, I <sup>2</sup> C) GPIO01	28
29	GPIO05		Ground	30
31	GPIO06		(PWM0) GPIO12	32
33	GPIO13 (PWM1)		Ground	34
35	GPIO19		GPIO16	36
37	GPIO26		GPIO20	38
39	Ground		GPIO21	40

### Raspberry Pi 4 B J14 PoE Header

01	TR01		TR00	02
03	TR03		TR02	04

### Pinout Grouping Legend

Inter-Integrated Circuit Serial Bus			Serial Peripheral Interface Bus
Ungrouped/Un-Allocated GPIO			Universal Asynchronous Receiver-Transmitter
Reserved for EEPROM			

Rev. 2  
19/06/2019 CGS

[www.element14.com/RaspberryPi](http://www.element14.com/RaspberryPi)



Next it is showed a table connection between external DC-37 female connector Pinout and Raspberry Pi 4B Pinout:

<b>DC-37</b>	Raspberry Pi GPIO	<b>DC-37</b>	Raspberry Pi GPIO	<b>DC-37</b>	Raspberry Pi GPIO	<b>DC-37</b>	Raspberry Pi GPIO	<b>DC-37</b>	Raspberry Pi GPIO
<b>1</b>	01	<b>09</b>	17	<b>17</b>	35	<b>25</b>	12	<b>33</b>	28
<b>2</b>	03	<b>10</b>	19	<b>18</b>	37	<b>26</b>	14	<b>34</b>	30
<b>3</b>	05	<b>11</b>	21	<b>19</b>	40	<b>27</b>	16	<b>35</b>	33
<b>4</b>	07	<b>12</b>	23	<b>20</b>	02	<b>28</b>	18	<b>36</b>	36
<b>5</b>	09	<b>13</b>	25	<b>21</b>	04	<b>29</b>	20	<b>37</b>	38
<b>6</b>	11	<b>14</b>	27	<b>22</b>	06	<b>30</b>	22	<b>38</b>	-
<b>7</b>	13	<b>15</b>	29	<b>23</b>	08	<b>31</b>	24	<b>39</b>	-
<b>8</b>	15	<b>16</b>	32	<b>24</b>	10	<b>32</b>	26	<b>40</b>	-



## 2 Tinker Touch

### 2.1 Controller Specifications:

Item	Tinker Board
<b>CPU</b>	Rockchip Quad-Core RK3288 processor,
<b>GPU</b>	2GB Dual Channel DDR3
<b>USB</b>	4x2.0 USB (1 is used for Touch)
<b>Storage</b>	Micro SD(TF) card slot
<b>Network Communication</b>	10/100 Ethernet (RJ-45)
<b>Wireless Communication</b>	802.11 b/g/n, Bluetooth V4.0 + EDR
<b>Low level devices</b>	8x GPIO, SPI, I2C, UART
<b>GPIO Voltage</b>	3,3V
<b>OS</b>	Linux Debian / Andorid

PANEL PC  
10,1"

LINUX  
LINUX OPERATION  
SYSTEM

ARDUINO  
Compatible with  
Arduino IDE

COM  
Industrial  
Communications

- This Panel PC is based on GNU/Linux OS or on Android OS installed on a SD card. It has many interfaces built in: Ethernet, USB, UART....Using the Ethernet port network you can remotely control all parameters, data and inputs/outputs of your control system.
- Furthermore, Tinker Board comprises enough I/Os to replace PLCs on simple automation applications.
- Open protocols not only allow communication with other Industrial Shields PLCs, but also third-party devices and machinery.
- In complex systems, you can create a network between several Tinker Board Touch. Providing integral supervision and control solution for entire production plants and real-time data at hand.



ANDROID



debian



## 2.2 Tinker Board Touch Pi I/Os Pinout

GPIO.Setmode (GPIO.ASUS)	GPIO.Setmode (GPIO.BOARD)	Pinout	Physical Pin Number	Pinout	GPIO.Setmode (GPIO.BOARD)	GPIO.Setmode (GPIO.ASUS)
	1	VCC3.3V_IO	1 2	VCC5V_SYS	2	
252	3	GP8A4_I2C1_SDA	3 4	VCC5V_SYS	4	
253	5	GP8A5_I2C1_SCL	5 6	GND	6	
17	7	GPOC1_CLKOUT	7 8	GP5B1_UART1TX	8	161
	9	GND	9 10	GP5B0_UART1RX	10	160
164	11	GP5B4_SPIOCLK_UART4CTS	11 12	GP6A0_PCM/I2S_CLK	12	184
166	13	GP5B6_SPIO_TXD_UART4TX	13 14	GND	14	
167	15	GP5B7_SPIO_RXD_UART4RX	15 16	GP5B2_UART1CTS	16	162
	17	VCC33_IO	17 18	GP5B3_UART1RTSN	18	163
257	19	GP8B1_SPI2TXD	19 20	GND	20	
256	21	GP8B0_SPI2RXD	21 22	GP5C3	22	171
254	23	GP8A6_SPI2CLK	23 24	GP8A7_SPI2CSN0	24	255
	25	GND	25 26	GP8A3_SPI2CSN1	26	251
233	27	GP7C1_I2C4_SDA	27 28	GP7C2_I2C4_SCL	28	234
165	29	GP5B5_SPIOCSN0_UART4RTSN	29 30	GND	30	
168	31	GP5C0_SPIOCSN1	31 32	GP7C7_UART2TX_PWM3	32	239
238	33	GP7C6_UART2RX_PWM2	33 34	GND	34	
185	35	GP6A1_PCM/I2S_FS	35 36	GP7A7_UART3RX	36	223
224	37	GP7B0_UART3TX	37 38	GP6A3_PCM/I2S_SDI	38	187
	39	GND	39 40	GP6A4_PCM/I2S_SDO	40	188

Tinker Board pinout:

Next, a table connection between external DC-37 female connector Pinout and Tinker Board Pinout is shown:

Tinker Board Pinout	External Pinout	DC-37	External Pinout	DC-37	External Pinout	DC-37	External Pinout	DC-37	External Pinout
1	-	09	GND	17	-	25	GND	33	RS232RX
2	5V+	10	RXD	18	GPIO24	26	CS1	34	GND
3	SDA	11	RE	19	MOSI	27	-	35	GPIO19
4	5V+	12	GPIO18	20	GND	28	-	36	TTL RX
5	SCL	13	DE	21	MISO	29	GPIO05	37	TTL TX
6	GND	14	GND	22	GPIO25	30	GND	38	GPIO20
7	GPIO4	15	GPIO22	23	SCLK	31	GPIO06	39	GND
8	TXD	16	GPIO23	24	CS0	32	RS232TX	40	GPIO21





### 3 General Specifications

Item		Touch Panel 10.1"
Power supply voltage	DC power supply	12Vdc to 24Vdc
Power consumption	DC power supply	22 VAC max.
External power supply	Power supply voltage	12V (30W) // 24Vdc (30W)
	Power supply output capacity	2.5A (12Vdc) // 1,25A (24Vdc)
Shock resistance		80m/s <sup>2</sup> in the X, Y and Z direction 2 times each.
Ambient temperature (operating)		0° to 40°C
Ambient humidity (operating)		10% to 90% (no condensation)
Ambient environment (operating)		With no corrosive gas
Ambient temperature (storage)		-20° to 60°C
Power supply holding time		2ms min.
Weight		2.250 gr.

### 4 Touch Screen Specifications

Item	Touch Screen
Technology	Resistive Multitouch LVDS, 315 nits, 170° viewing angle
Image Resolution	1280 x 720
Format	16:9
Size	10.1"



## 5 Power Supply

DC Power Supply: 12V (30W) // 24Vdc (30W)

Current: 2.5A (12Vdc) // 1,25A (24Vdc)

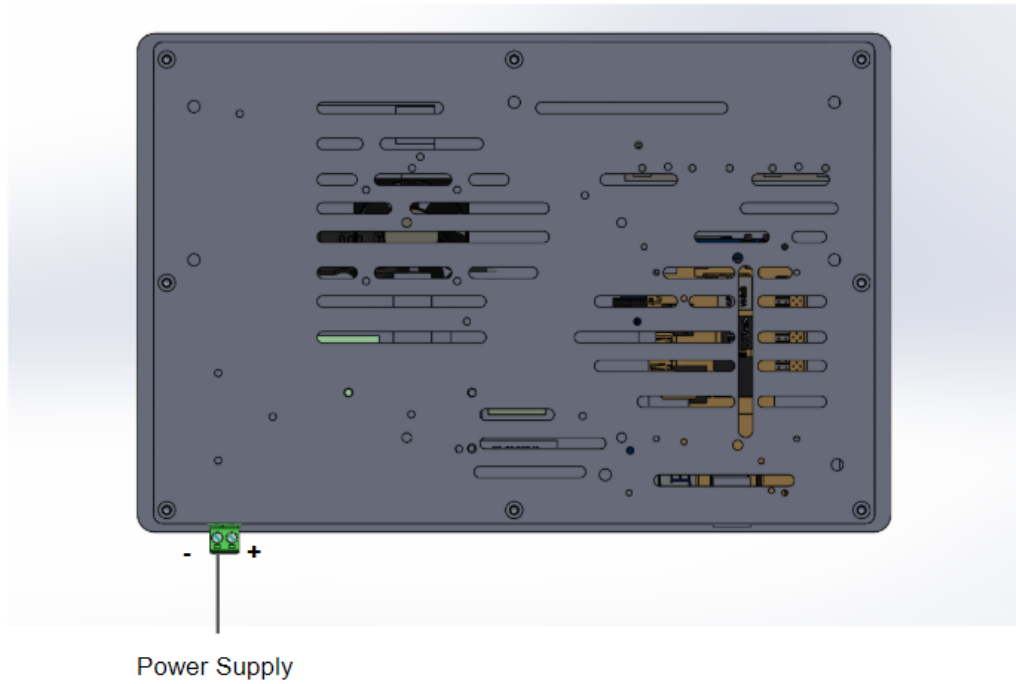

Power supply: 12/24 Vdc



- Plug-in connector
- Pitch: 5,04 mm
- Two contact pins



## 6 Communication Connections

The communication connections are located in the lower part of the panel, at the right part, as you can see in the image below:

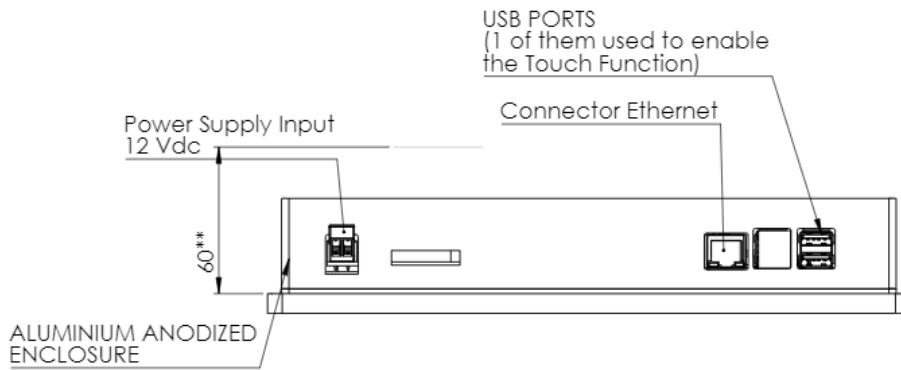

Ethernet and USB port connectors (One of the USB ports is connected in order to activate the attach function)

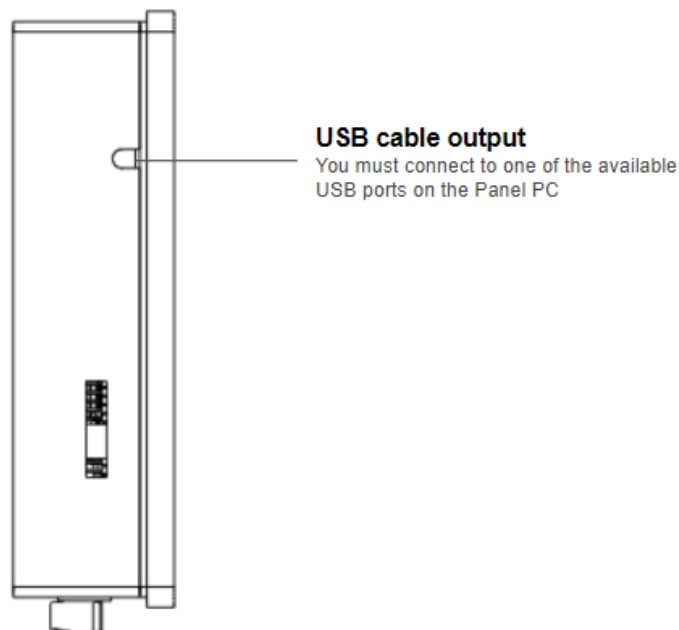



## 7 Screen configuration

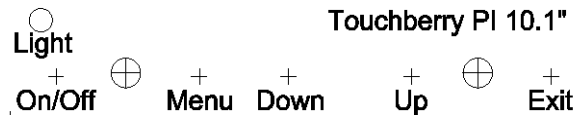

**Light:** Operation indication led.

**On/Off:** Switch ON/OFF the device.

**Menu:** choose and select the configuration mode.

**Down:** move down on the configuration menu.

**Up:** move up on the configuration menu.

**Exit:** Select the screen operation mode (HDMI operation mode).

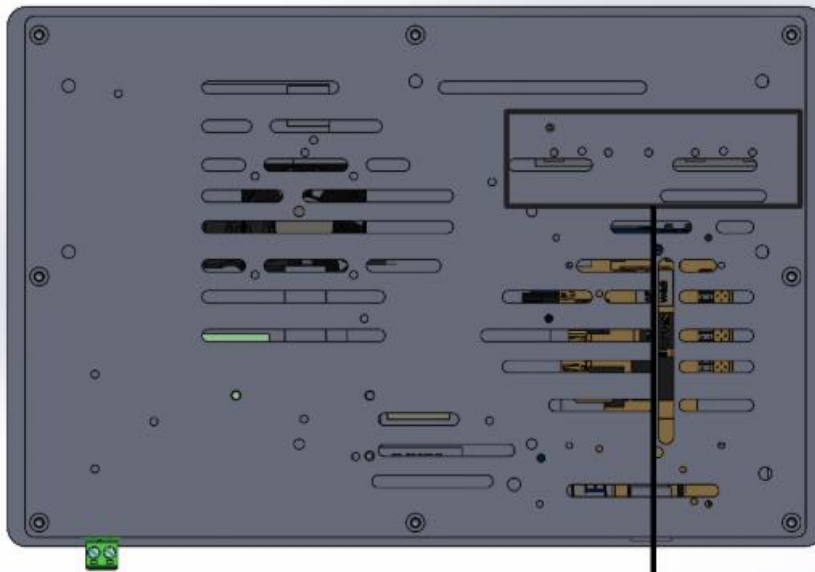

Screen menu  
configuration buttons



## 8 Touch Panels PC 10.1" Size:

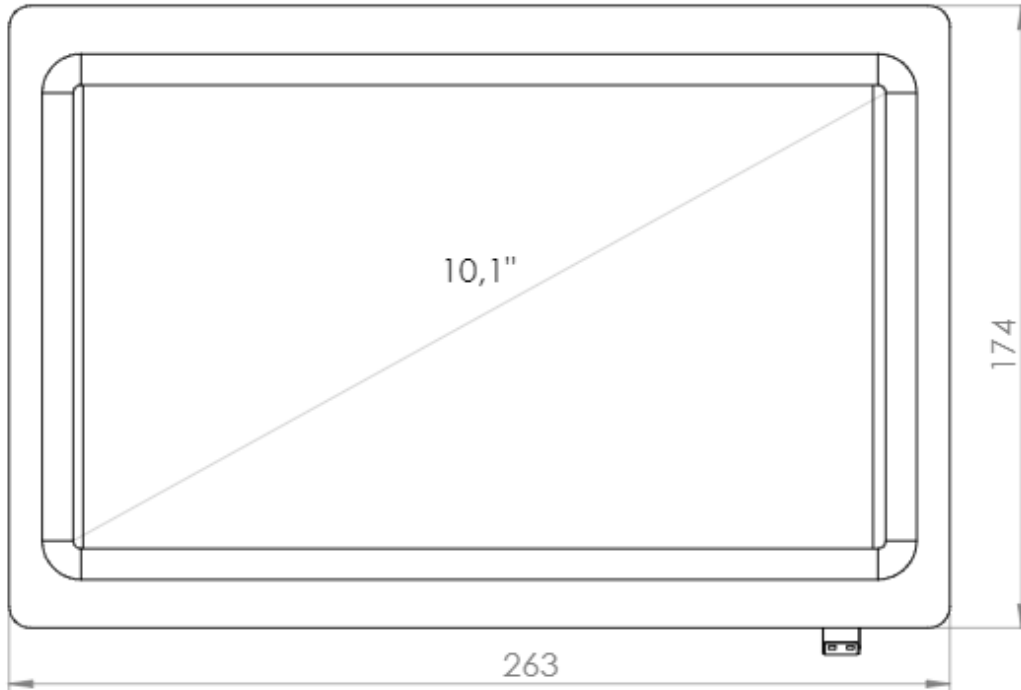

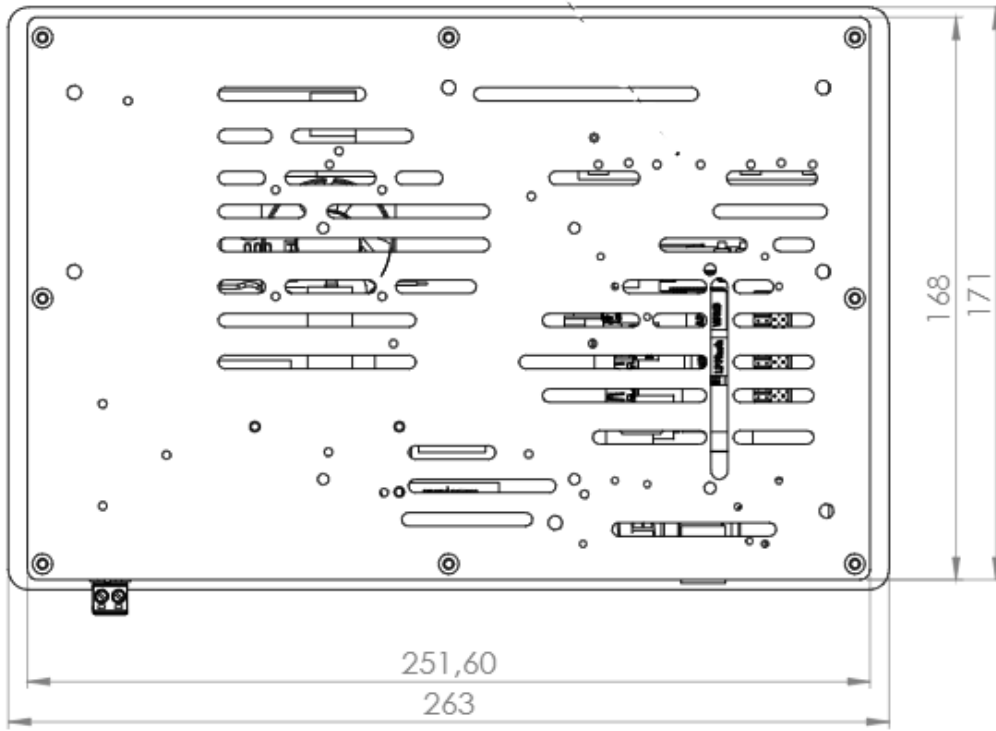



## 9 Mechanical assembly configuration:

### 9.1 Panel mounting

Mechanical assembly place (Dimensions in mm):

\*NOTE: Space available for assembly. Free space of external elements.

\*\*NOTE: See minimum depth required for right ventilation

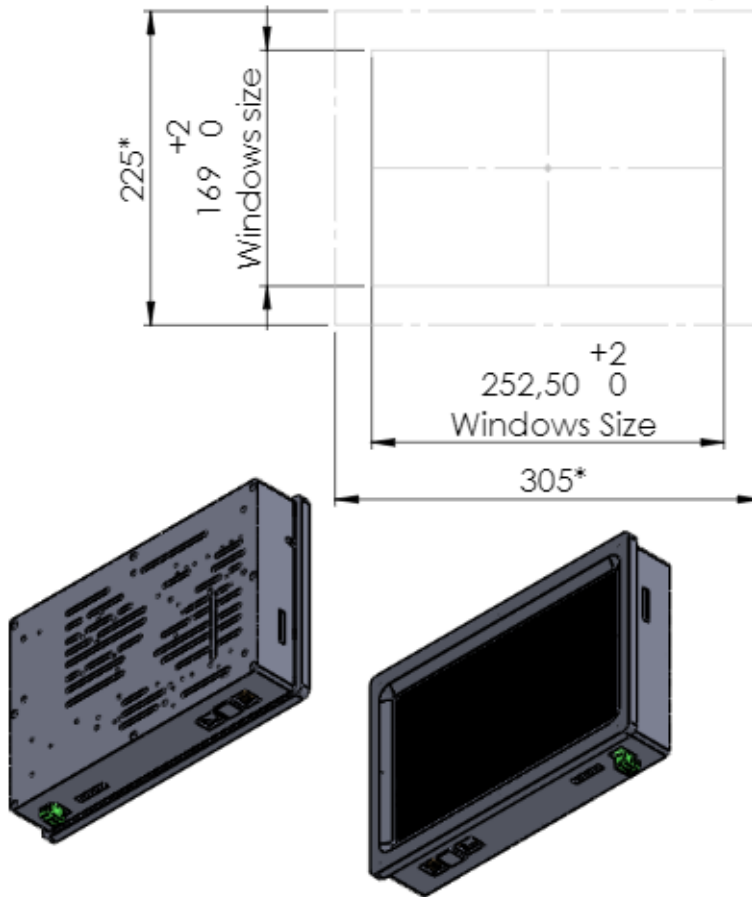



## 9.2 Standard VESA

Our panels are based on the VESA assembly standard (VESA 75 standard):

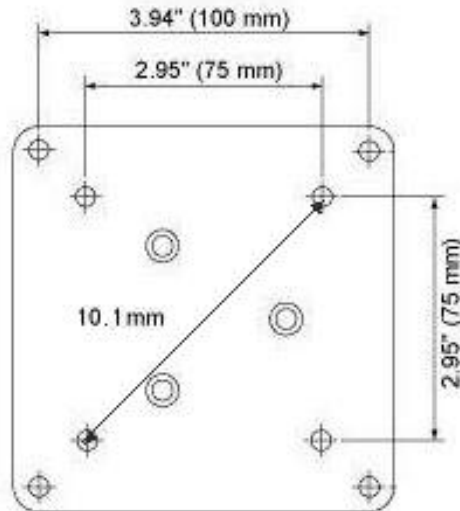

## 9.3 Trim Plate

The trim plate, is **NOT a product included in the Touch10.1"**, you can buy it through our website.

It is an embellisher for the Panel screen,

The measurements for the assembly are specified below:



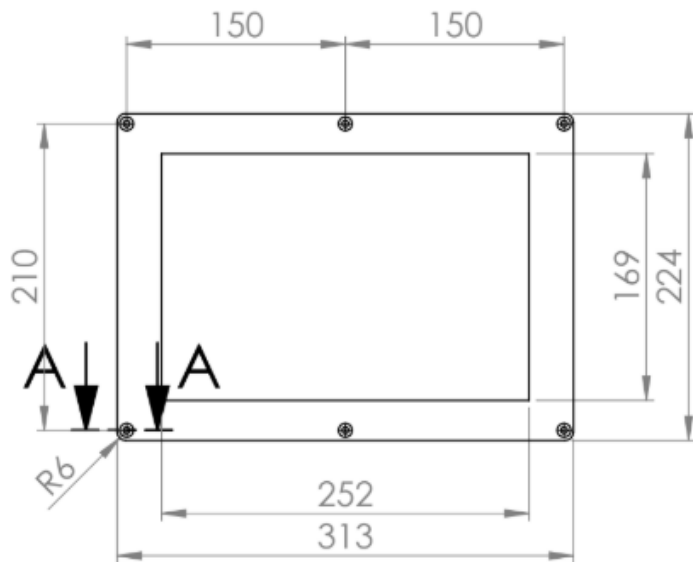
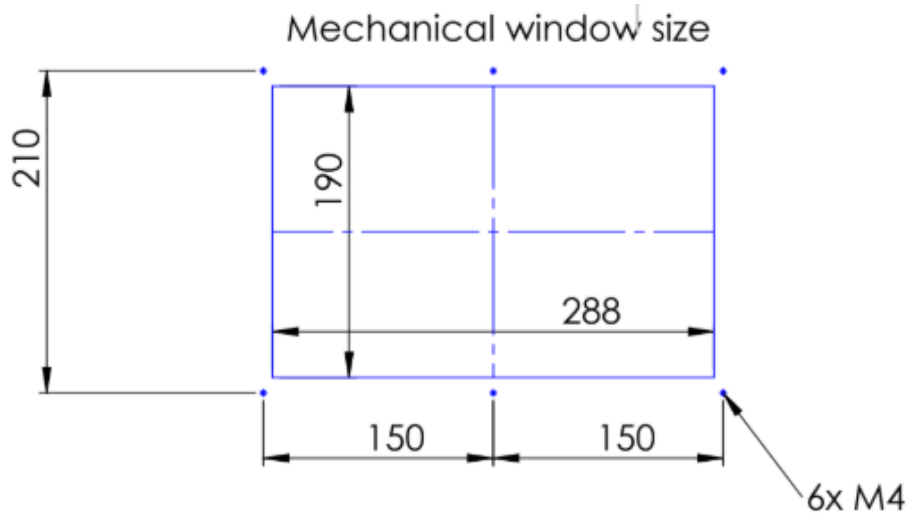

## Section A-A

SCALE 2 : 1

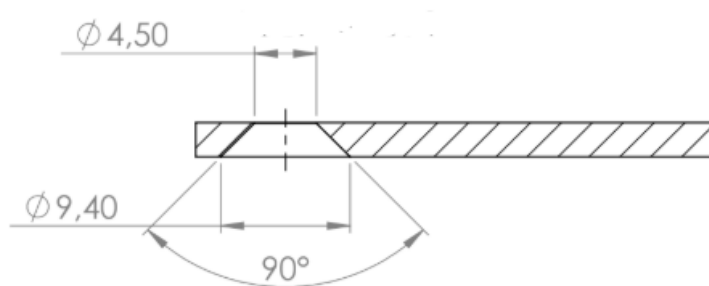



## 10 Operating System on Touch Panels

### 10.1 Debian

Debian is Unix-like computer operating system that is composed entirely of free software.



Raspbian, Bananian and Debian Jessie are shorts adaptations of Debian 8 for embedded systems. Debian has a long available row of packages. Also it is possible to develop your own applications, servers, web servers, etc. For example using Node Red, NodeJS, Qt libraries, DB SQL, Mongo DB, etc.

More information on: <https://www.debian.org/>

### 10.2 How to create apps

#### TouchBerry Pi:

These steps are based on how to download cross-compiler for Raspberry for your own applications.

\* Qt, or text program compilations for Touchberry.

From a Linux PC, download "git" app.

From a console do:

```
$ yourpath> git clone https://github.com/raspberrypi/tools.git
```

Now, you have the cross-compiler for Raspberry. Export some variables, and add the compiler path to the environment path variable:

```
PATH=$PATH:<yourpath>/tools/arm-bcm2708/gcc-linaro-arm-linux-gnueabi-hf-  
raspbian/bin  
export ARCH=arm  
export CROSS_COMPILE=arm-linux-gnueabi-hf-
```

Now, you can compile your C++ program doing:

```
$> arm-linux-gnueabi-hf-g++ -o yourprogram yourprogram.cpp
```

If you want to create a project with Qt, you need compile the Qt sources for Raspberry. First, you will need to download for example:

<http://mirror.netcologne.de/qtproject/archive/qt/5.4/5.4.1/single/qt-everywhere-opensource-src-5.4.1.tar.gz>

Now with your arm-linux-... compiler, you can compile these sources for Raspberry. You can create a project with a Desktop Qt system. (Same as doing it for PC). Finally, you'll have to configure your Qt IDE in order to use the qt-everywhere sources compiled instead of the Desktop ones.



It'll result in a graphical program for the Touchberry Pi Model!

### 10.3 Other interesting available software

Also there are many software's available to run on Debian, next it is showed different link where you can see examples and how to use these software's, also on our blog there are interesting information regarding our Touch Panels:

Node JS: <http://blog.industrialshields.com/en/tcp-server-on-touchberry-pi-3-with-node-js/>

RapidScada: <http://blog.industrialshields.com/en/how-to-install-and-use-rapid-scada-on-touchberry-pi-and-bananatouch/>

Firmata: <http://blog.industrialshields.com/en/software-for-iot-solutions/>

Node-Red: <http://blog.industrialshields.com/en/software-for-iot-solutions/>



## 10.4 Android

Android is an Operating System Open Source developed by Google, based on Linux kernel and designed primarily for touchscreen mobile device such smartphones and tablets. Android on Industrial Shields Touch Panel PC's functionality is like an Android tablet.

Android software can only work on the TinkerTouch Panel PC model, but it's not allowed on the Touchberry Pi 4B Model.

## 11 Kiosk Mode on Panel Touch 10.1”

On Raspbian / Linux:

### Procedure

- 1- Locate the autostart file into `/home/pi/.config/lxsession/LXDE-pi/autostart`
- 2- Remove the content of the autostart file
- 3- Add a line to the autostart file with the browser command in kiosk mode prefixed by an @:  
`@chromium-browser --kiosk --app= http://127.0.0.1:8080`
- 4- Reboot the rpi

### Fast way

- 1- Execute the next line command:

```
echo "@chromium-browser --kiosk --app=http://127.0.0.1:8080" >
/home/pi/.config/lxsession/LXDE-pi/autostart
```